

Company

- ViShare Technology Limited is a Hong Kong based fabless semiconductor company established in 2012.
 - Invested by VC
- Benefiting from its patented technologies, ViShare's codec chips make it possible to stream 4K or even 8K videos over standard 5G and Wi-Fi with a market leading performance in latency, video quality and reliability.
- Our mission: Popularize the application of ViShare Streaming Technology (ViST) in consumer products, as well as make ViST become an industrial standard similar to WiDi, WHDI, HDBaseT, etc.



What Problem do We Solve ?

- Currently, a video source is connected to a display via an HDMI cable. However, there are increasingly more user demands on connecting the video source to the display wirelessly via WiFi or 5G mobile network to transfer the video.
 - Scenarios which require wireless streaming: Cloud gaming, PC-to-TV game streaming, cable-free VR gaming, etc.
- These wireless applications require video codec (compression/decompression) to meet the cable replacement requirements of near-zero latency, visual lossless quality and high reliability. However, existing video codec chips in the market are designed to maximize compression rate for storage as well as internet download, and they are unable to fulfil these requirements.



- To fill this market gap, ViShare is developing a video Codec chip optimized for real-time wireless streaming and it will have cable-like performance without compromise in latency, video quality and reliability.

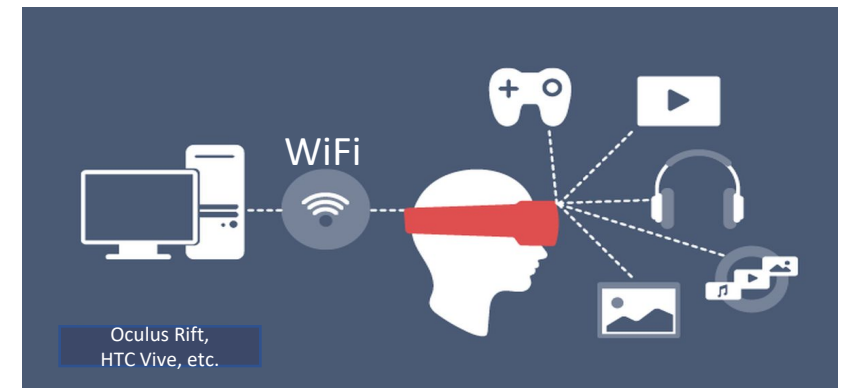

ViShare Video Streaming Technology

ViShare Streaming Technology

Combines the advantages of uncompressed technology and traditional compressed technology

Advantages

- Ultra-low latency:** ~1 frame or 16.7ms for 60fps
- Good video quality:** Visually lossless
- High reliability:** Highly stable in wireless streaming
- Long distance:** Its standard IP packets can be sent over WiFi or 5G mobile network

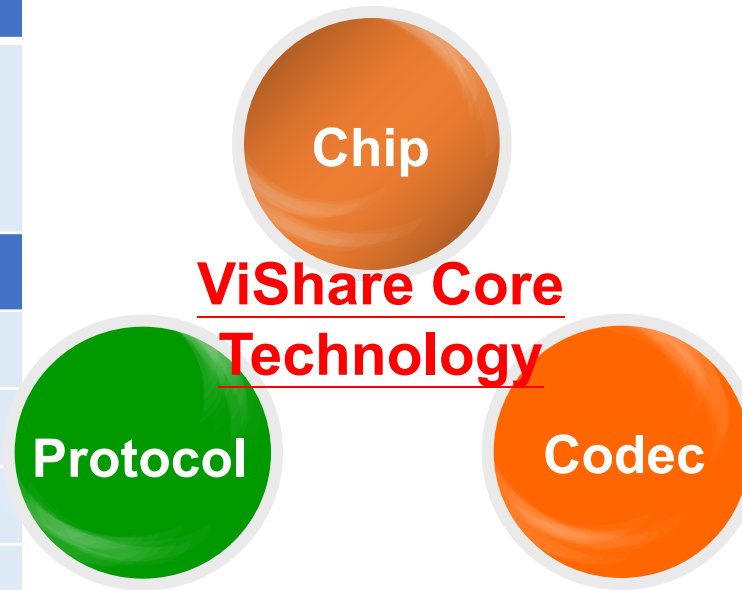

ViShare's 3 Core Technologies

Codec Chip: Patented parallel processing architecture dedicated for video compression and decompression

Codec Algorithm: The patent-pending error correction algorithm can solve the latency and reliability issues in wireless streaming

Communication Protocol: The patent-pending protocol can solve the latency issue in wireless streaming

Existing Wireless Video Streaming Solutions

Uncompressed Technology

Traditional H.264/265 Compressed Technology

Uncompressed Technology		Traditional H.264/265 Compressed Technology	
Advantages	Disadvantages	Advantages	Disadvantages
<ol style="list-style-type: none"> Low latency: <10ms Good video quality: Lossless 	<ol style="list-style-type: none"> Require large bandwidth: 18Gbps(18,000Mbps) for 4K/60fps video Short transmission distance: <10m Require line-of-sight: Transmitter and receiver need to point-to-point face to each other without obstacles in between 	<ol style="list-style-type: none"> Require small bandwidth: ~100Mbps for 4K/60fps video Long transmission distance: 30~100m depending on the WiFi module performance 	<ol style="list-style-type: none"> High latency: ~200ms Relatively poor video quality: Obvious compression artifacts Unstable: Video jittering or drop frames may appear when interfered by other WiFi signals

Benchmarking



We set up the benchmarking by using our VT4060 FPGA codec chip EVBs, one as a transmitter and one as a receiver, to stream 4K/60fps video over 802.11ac WiFi. The left display is the original video output through an HDMI cable and shows the time stamp of 250~267ms. The right display is the video streamed over WiFi used our encode/decode EVBs and shows the time stamp of 250ms. Therefore, the glass-to-glass latency is 0~17ms.

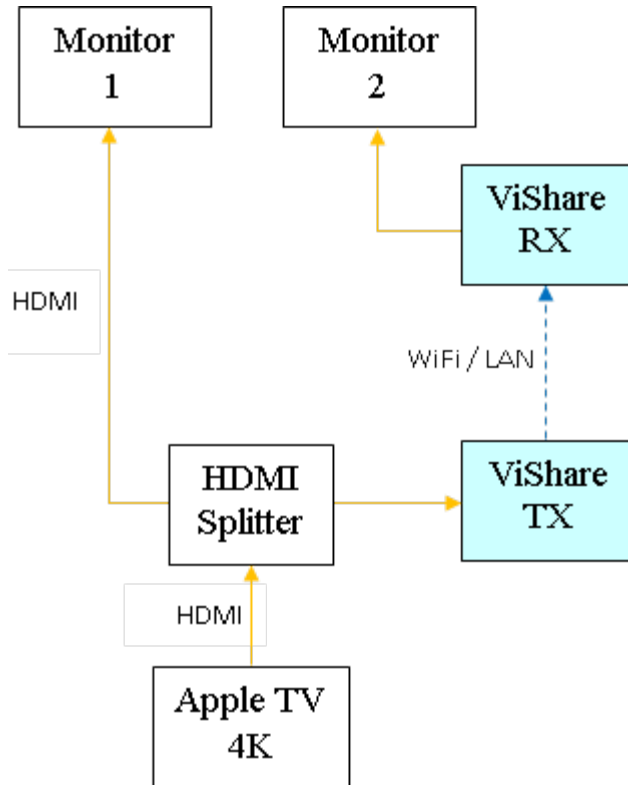

VT4060 FPGA EVB (TX)



VT4060 FPGA EVB (RX)

Perfect Match with 5G Mobile Network

ViShare Codec + 5G Network = Beyond Imagination

- ViShare Codec: Ultra-low latency, visual lossless and low bit-rate
- 5G mobile network: Ultra-low latency and high bandwidth

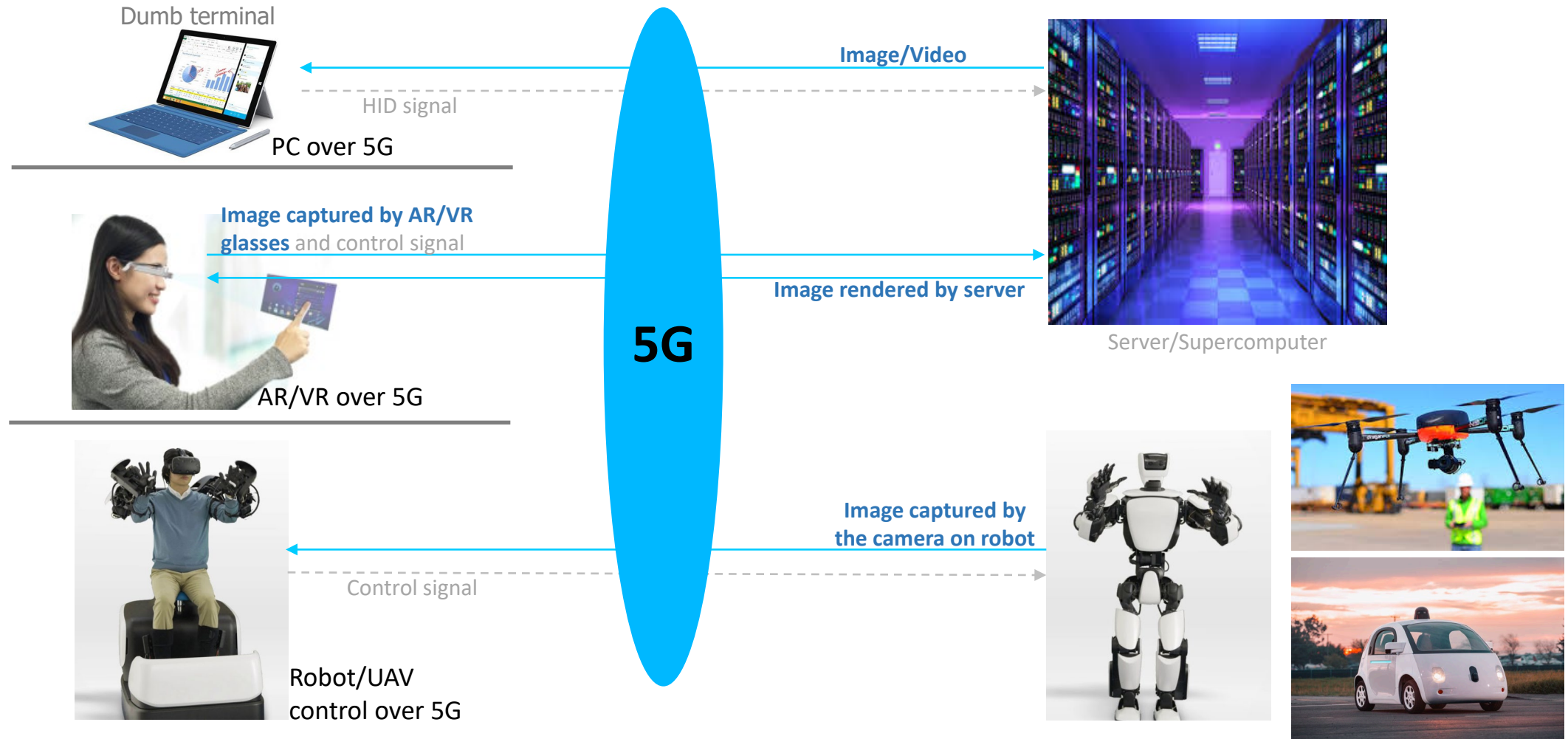

Wireless Projector

- Plug and play
- Wireless connect laptop to projector in conference room
- Wireless connect set-top box, blu-ray player, game console, PC, etc. to projector in living room
- The inevitable trend of projectors

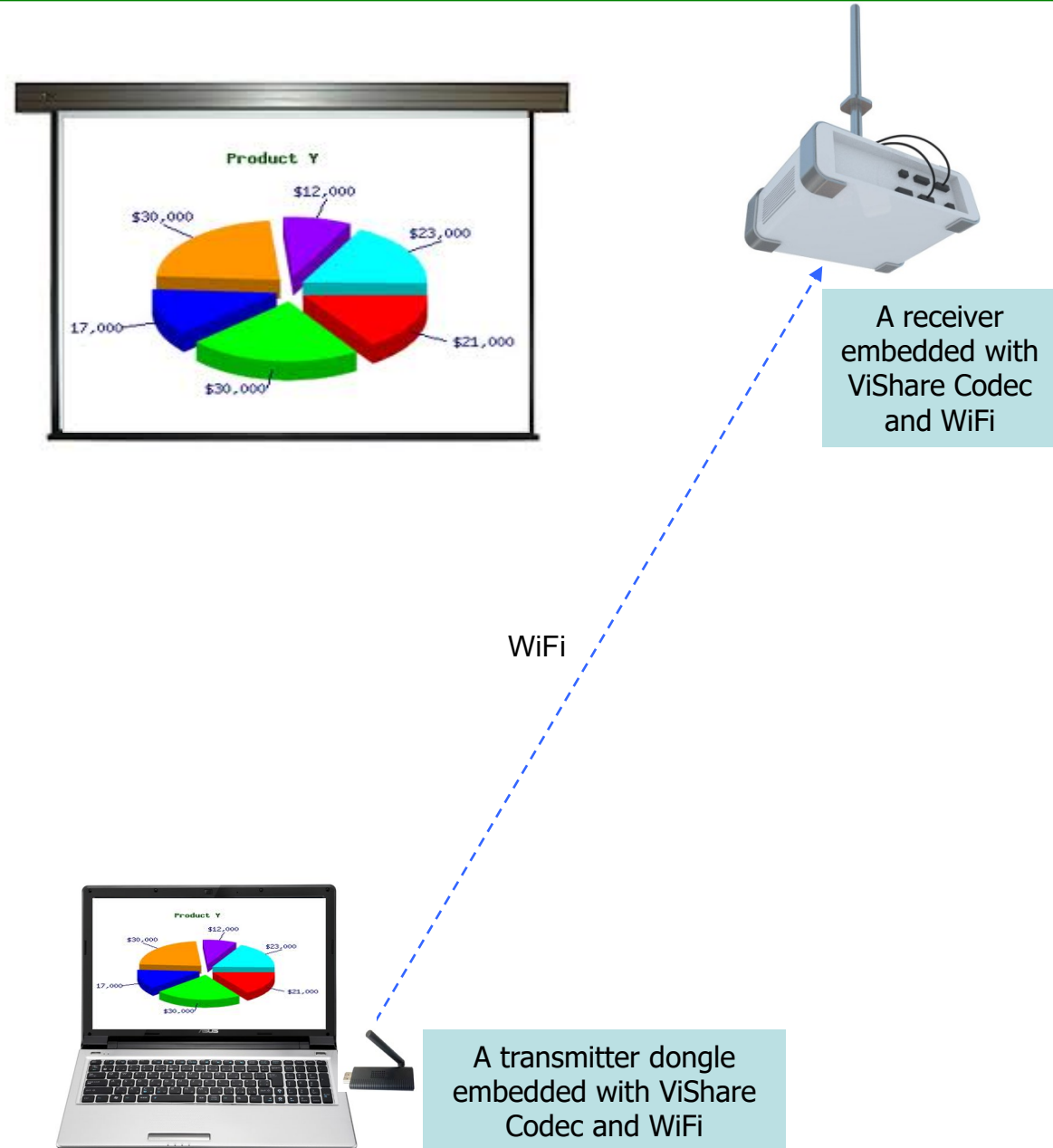

Wireless AV Sender

- Wirelessly stream video from **any video source** to **any display**
 - Source: PC, settop box, Blu-ray player, etc.
 - Display: TV, monitor, projector, etc.
- Our Codec chip can be embedded in a set-top box, PC display card, etc., or made as a standalone device

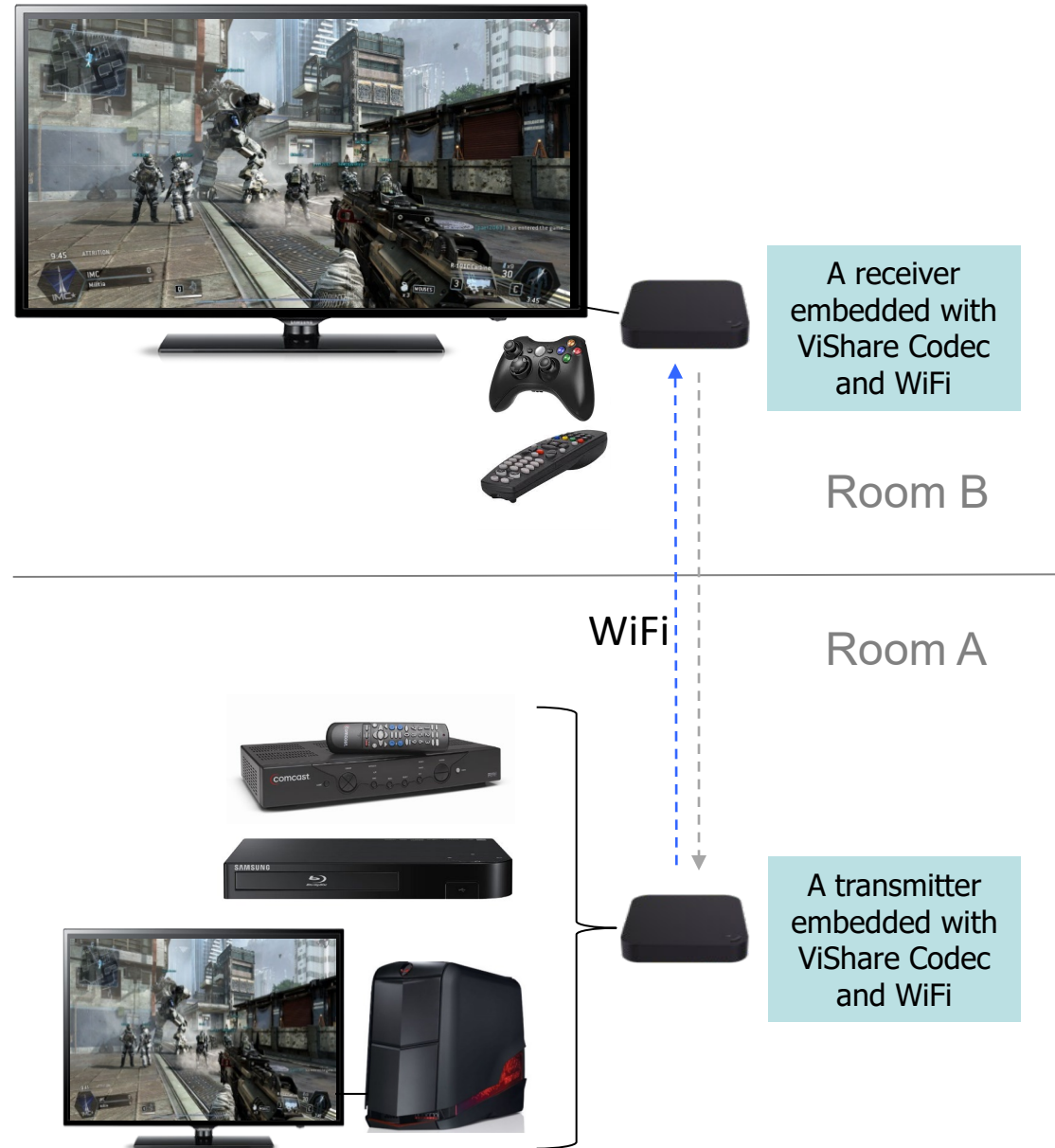

Wireless VR/AR HMD

- Embed the ViShare VT4060 into the HMD, or use a portable receiver dongle connecting the HMD
- Wirelessly stream all the game and video contents from PC, Xbox, Playstation, etc. to the HMD
- Get rid of the HDMI cable from the VR/AR HMD

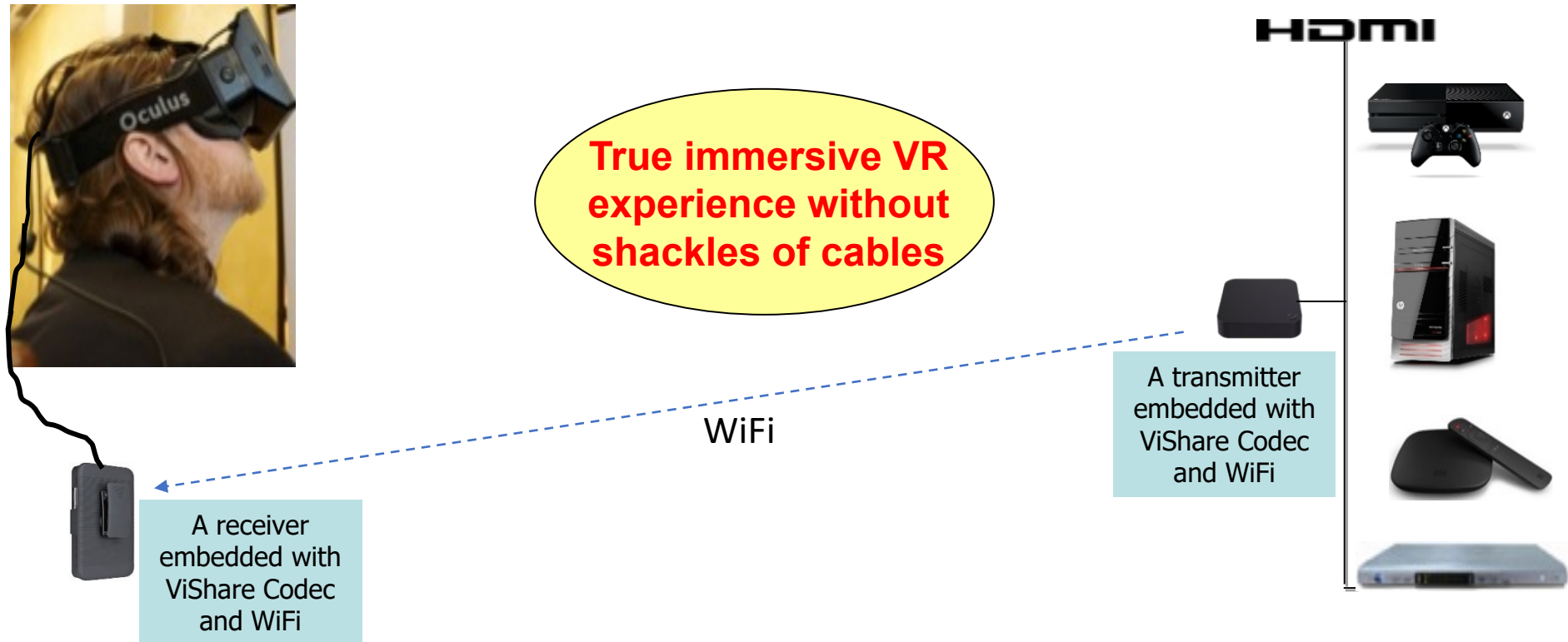

VT202 Codec Chip

- Already mass production
 - Resolution/frame rate : 720p/60fps, 1080p/30fps
 - End-to-end latency
 - ✓ H/D encode → H/D decode : 32ms
 - ✓ H/D encode → S/W decode : ~70ms
- Design-win into the Tencent Android game console
 - Designed by Tencent and operated by Lenovo
 - Lemon MiniSatation(乐檬微游戏机)
 - ✓ <https://ms.qq.com/product/2016041111462099575110.htm>
 - ✓ While outputting the video to a TV through HDMI cable, the game console simultaneously streams the video to a Smartphone through WiFi. The user can use the Smartphone as gamepad to play the game and input data



VT4060 Codec Chip

- Implemented in Xilinx K7-325T
 - Resolution/frame rate : 4K/60fps or 2.7K/120fps
 - Support both low-latency proprietary codec and standard compliant H.264 codec
 - Encode+decode latency : ~1ms
 - End-to-end latency(Encode + network + decode)
 - ✓ Ethernet : ~1ms
 - ✓ WiFi : 8~16m
- Development status
 - VT4060-FPGA available now
 - Plan to tape-out ASIC soon



VT4060 FPGA Encoder Board



VT4060 FPGA Decoder Board

ViShare Technology Limited



))))) wireless 4K)))))



- Contact : Derick Hui
- Tel. : 2778 2898
- Email : derick@visharetech.com
- Website : www.visharetech.com